

An Enterprise Solution for High Mix RF Testing

CodeOne™ allows a flexible and highly integrated PNA-X architecture to be configured for the various measurements. Automatic measurements such as CW, Pulsed, NF and Inter-modulation Product are extremely fast since the DUT control and handshaking happens simultaneously. CodeOne™ manages both the DUT and the PNA, and offers a wide variety of built-in features, such as calibration wizard, advanced data processing and display capabilities (e.g. graphical overlay) and extremely powerful automatic test report generation.

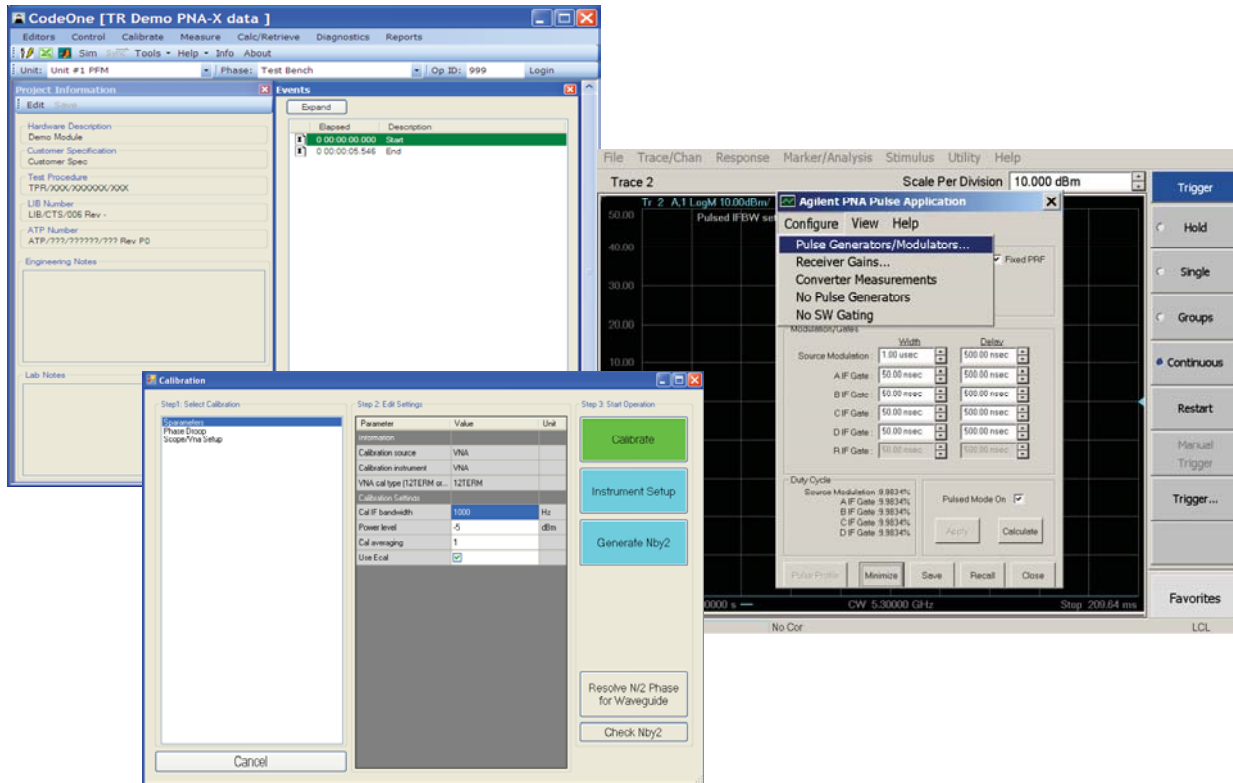

CodeOne™ User Panels

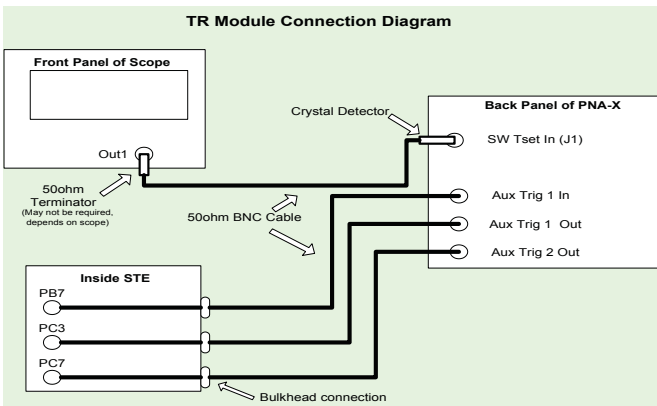

Typical TR Module Test Setup

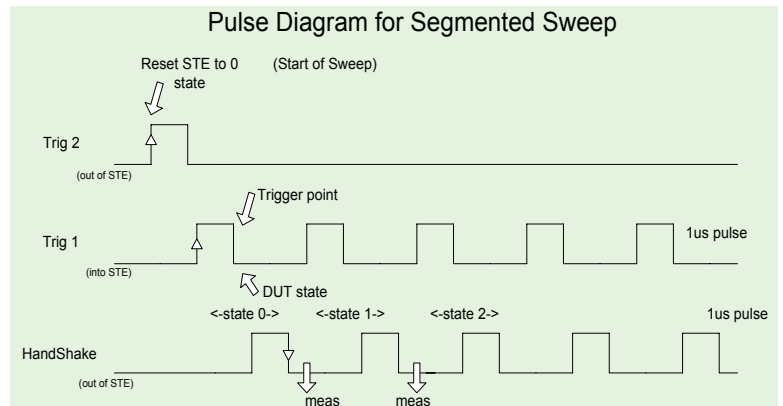

Typical Measurements Timing Diagram